



# *Installation Manual*

*Footrests*

*Model: **COMFORT***



**probrake.de**

### General Safety Instructions for Installing Footpegs



Installing footpegs requires technical understanding and solid mechanical skills. Incorrect installation can lead to serious accidents and damage to the motorcycle. Please observe the following safety instructions:

#### Before Installation

- Tools: Use only recommended, suitable tools.
- Know-how: Perform the installation only if you have sufficient knowledge.
- Questions or issues: Contact a workshop with appropriately qualified personnel.
- Stability: Secure the motorcycle on a paddock/maintenance stand so it is stable.
- Read first: Read this manual carefully and completely before starting

#### During Installation

- Protective gear (as needed): Gloves, sturdy footwear, and safety glasses.
- Torque: Tighten bolts to the specified torque (use a torque wrench).
- Inspect parts: Check all components for damage before installing.
- No force: Work precisely and do not force components.

#### After Installation

- Safety check: Verify the secure fit of all screws and components.
- Test ride: Perform a careful test ride and watch for irregularities.

#### General Notes

- Warning: Depending on setup and adjustment, this product can reduce cornering and ground clearance at lean.
- Use only original or approved replacement parts.
- Check regularly for secure fit and wear.
- probrake GmbH assumes no liability or warranty for any damage resulting from combinations with accessories not tested by probrake, from improper installation, or from insufficient maintenance.
- Depending on design, probrake footpegs are individually adjustable. The setting depends on the vehicle's construction and available space and must ensure free operation of brake and shift levers as well as clearance to all components (incl. swingarm) throughout the full suspension travel.



#### ABE – General Operating Permit (Germany)

- The ABE (General Operating Permit) must always be carried with the vehicle in Germany.
- Observe all notes, information, and stipulations in the ABE.
- This ABE is valid only for the listed models and only if all stipulations are observed.
- For vehicles not listed here, an entry in the registration documents is required.
- Outside Germany, different legal regulations may apply.

### Scope of Delivery (per side)

1. Footpeg body COMFORT
2. COMFORT tread surface
3. Axle/pin
4. Return spring
5. Position ring
6. Mounting adapter (vehicle-specific)

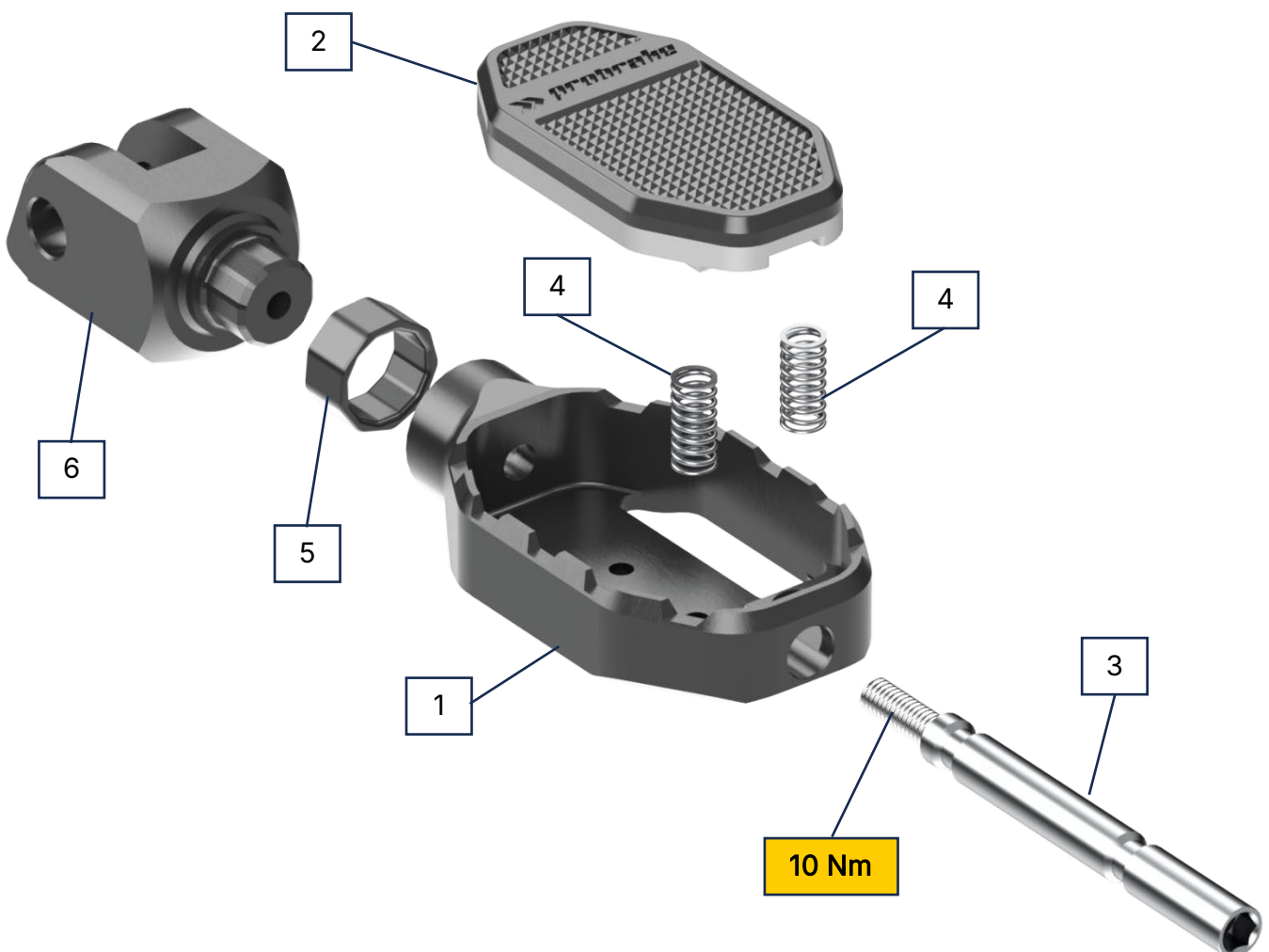

### General Installation Notes – probrake Footpegs

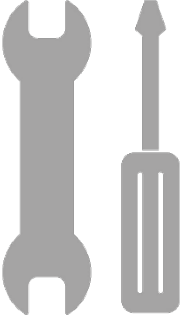
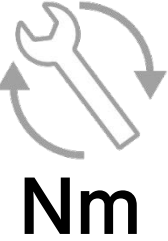
	<p><b>Preparation</b></p> <ul style="list-style-type: none"><li>• Park the motorcycle securely.</li><li>• Lay out tools within easy</li></ul> <p><b>Removing the OEM Footpegs</b></p> <ul style="list-style-type: none"><li>• Remove the original footpegs. Take out cotter pin, retainer, brackets, nut, or bolt. On some vehicles these are riveted; in such cases they must be drilled out and later reinstalled using the supplied screws.</li><li>• Install the vehicle-specific mounting adapters in reverse order of removal, using OEM or supplied parts.</li><li>• Observe torque specifications and reinstall OEM cotter pins, retainers, and nuts per the manufacturer's instructions.</li><li>• <b>Secure all screw connections with threadlocker.</b></li></ul> <p><b>Important General Notes</b></p> <ul style="list-style-type: none"><li>• As a rule, the original fastening hardware is reused for installation.</li></ul> <p><i>💡 Tip: Dismantle and install one side first. Once finished, use it as a reference for the second side.</i></p> <ul style="list-style-type: none"><li>• Observe the stipulations of the operating permit.</li><li>• After the test ride, check all screws for tightness.</li></ul>
	<p><b>The following must be observed during installation:</b></p> <ul style="list-style-type: none"><li>• All M6 screws: tighten to 10 Nm.</li><li>• All M5 screws: tighten to 6 Nm.</li><li>• Use medium-strength threadlocker on all screw connections. Exception: when using self-locking nuts.</li></ul>

### Special Installation Notes - COMFORT

#### COMFORT

- Use the position ring [6] to position the footpeg body [1] (Figure A).
- Clamp the springs [4] into the dedicated pockets between footpeg body [1] and tread surface [2]. Then secure the tread surface [2] in the footpeg body [1] with the axle [3].
- Tighten the footpeg body [1] with axle [3] to the adapter [6] to 10 Nm.

---

#### Extension Arms / Offset Brackets (optional)

- Extension arms can be used to move the peg position downward, upward, forward, or backward (Figure B).
- The countersunk screw **M6×16** must always be tightened to **10 Nm** at the adapter.
- Choose a position that ensures clearance for **all** components and good accessibility of shift and brake levers in **all** positions.
- **Note for passenger pegs:** raising the peg may affect the folding function. Additional modifications may be necessary.
- Available versions: 25 mm extension; 30/50 mm extension (usable in two orientations).



Boom 25 mm



Boom 30/50 mm

Adjusting the Footpeg Position - COMFORT

Figure A

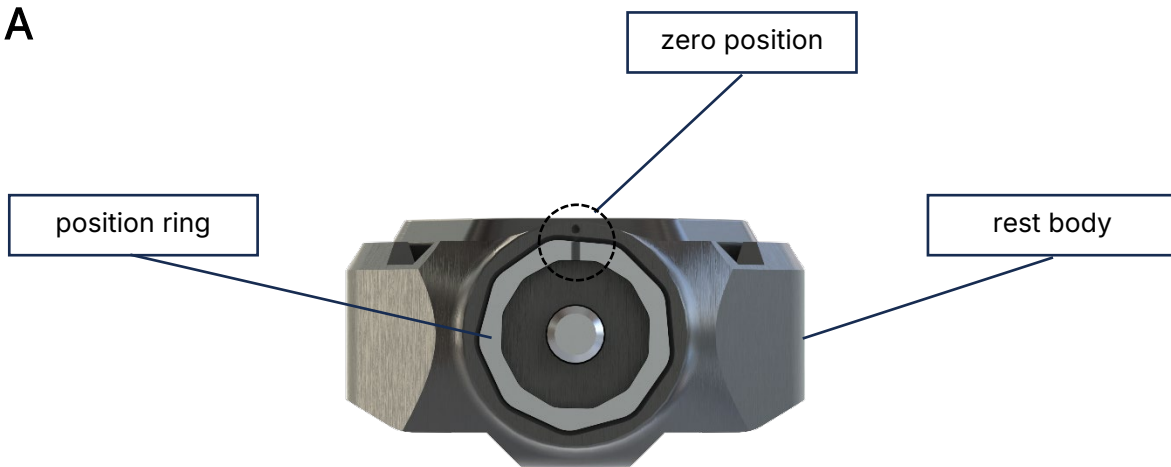

Remove and rotate the **position ring** to find the desired footpeg position. Each rotation (horizontal & vertical) provides a new setting through fine alignment of the inner and outer faces.



The ring has 12 faces on the outside and 12 faces on the inside. Each face is offset by 30°; the inner faces are twisted by 3.5° relative to the outer faces. This results in 103 possible positions to individually adjust the peg body. The notches mark the zero position.

Adjusting the Footpeg Position with Extension Arms

Figure B

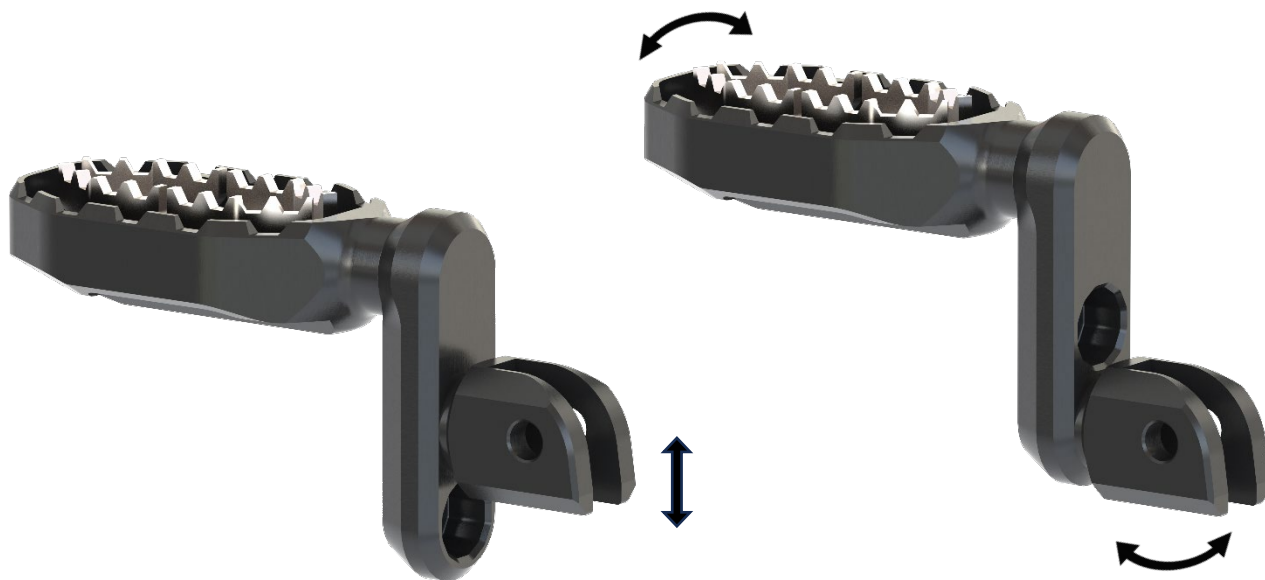
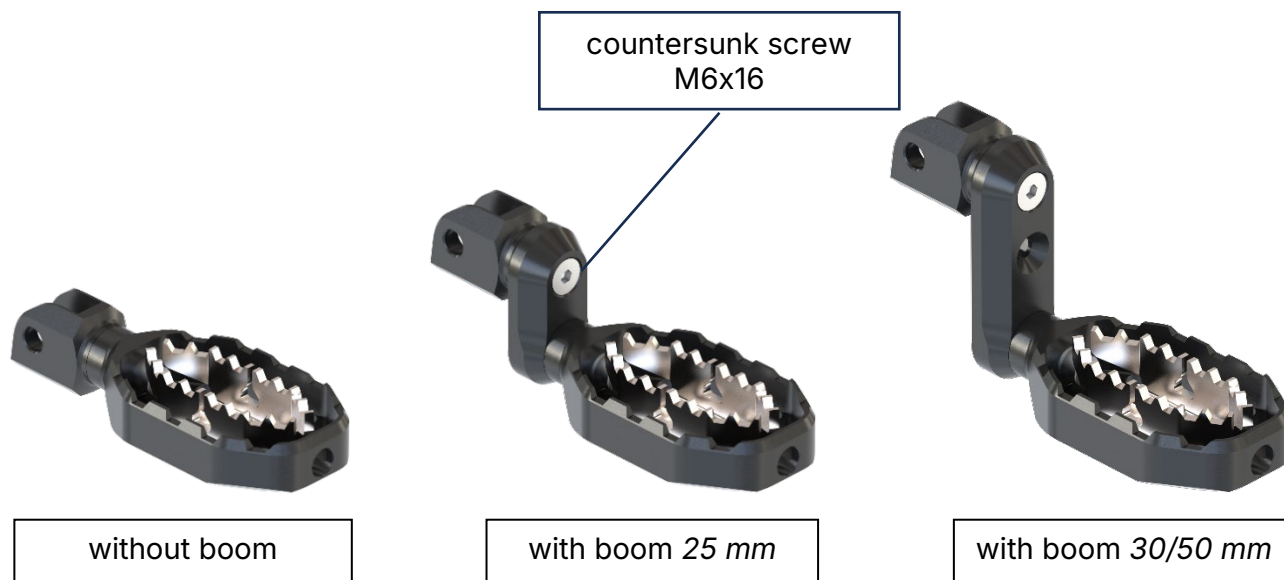

### Mounting Kits (optional)

<p>Z0316</p> 	<p>Z0311</p> 	<p>Z0317</p> 
<p>Z0307 / Z0324</p> 	<p>Z0312 / Z0314 (on both sides) Z0315 (one-sided)</p> 	<p>Z0315</p> 
<p>Z0322</p> 	<p>Z0309</p> 	<p>Z0310</p> 

Installing the mounting adapters is vehicle-specific and is carried out in reverse order of removal using the original cotter pin/retainer and/or the included mounting hardware. Observe the screw torque specifications from the vehicle service manual. Reinstall original cotter pins, retainers, and nuts according to the manufacturer's instructions.

**Screws must always be secured against self-loosening.**



Exemplary assembly illustration

# Here are some more probake quality products

## STEEL BRAIDED HOSES



## FOOTRESTS



## BRAKE & CLUTCH LEVER



## CRASH PADS & SAFETY



## HANDLEBARS



## BRAKE DISC & BRAKE PADS



## ACCESSORIES & ATTACHMENT



## STEEL BRAIDED KITS CARS



probrake GmbH  
Fritz-Schieler-Str. 3  
D-79331 Teningen

**probrake.de**

info@probrake.de

