

» *probrake*

Installation Manual

Handlebar ends

Model: CONE



probrake.de

General Safety Instructions for Installing probrake Handlebar Ends



Installing handlebar ends requires technical understanding and solid mechanical skills. Incorrect installation can lead to serious accidents and damage to the motorcycle. Please observe the following safety instructions.

Before Installation

- Tools: Use only recommended, suitable tools.
- Know-how: Perform the installation only if you have sufficient technical knowledge.
- Questions or issues: Contact a workshop with appropriately qualified personnel.
- Stability: Secure the motorcycle on a paddock/maintenance stand so it is stable.
- Read first: Read these instructions carefully and completely before starting

During Installation

- Protective gear (as needed): Gloves, sturdy footwear, and safety glasses.
- Torque: Tighten screws to the specified torque (use a calibrated torque wrench).
- Inspect parts: Check all components for damage before installation.
- No force: Work precisely and do not force components.

After Installation

- Safety check: Verify the secure fit of all screws and components.
- Steering movement: Full steering lock must be smooth and unobstructed.
- Geometry: Align bar ends correctly and avoid any tension.
- Test ride: Perform a careful test ride and watch for irregularities

General Notes

- For questions or problems, contact a workshop with appropriately qualified personnel.
- Replace damaged parts immediately; otherwise proper function cannot be guaranteed. Any manipulation such as welding, soldering, bending, or drilling is prohibited.
- probrake GmbH assumes no liability or warranty for any damage resulting from combinations with accessories not tested by probrake, from improper installation, or from insufficient maintenance



Operating Permit (Germany)



- The handlebar ends are registration-free.
- No ABE or parts certificate is required.
- Outside Germany, different legal regulations may apply

Scope of Delivery – Model CONE (per side)

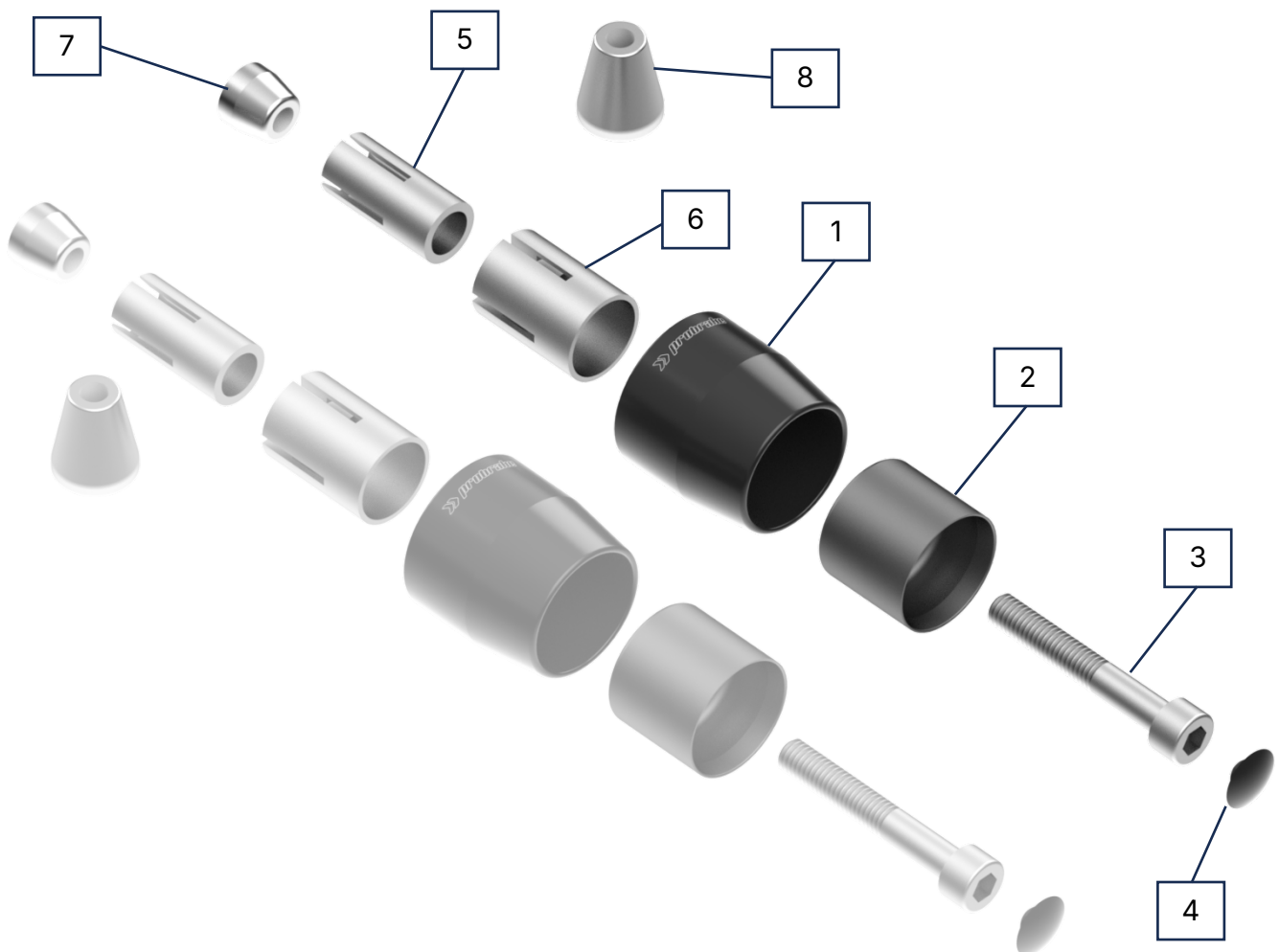
1. Handlebar end body CONE
2. Handlebar end inlay – CONE
3. Socket head cap screw M6×50 (DIN 912)
4. Screw-head cover
5. Expansion sleeve small (12–15 mm)
6. Expansion sleeve large (17–21 mm)
7. Cone small
8. Cone large
9. Optional: vehicle-specific mounting kits "LGA"

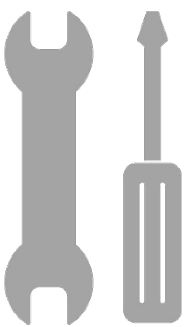

Installation Notes – probrake Handlebar Ends

	<p>Preparation</p> <ul style="list-style-type: none">• Park the motorcycle securely.• Lay out tools within easy reach. <p>Installation of probrake handlebar ends</p> <ul style="list-style-type: none">• Pre-stage parts according to the illustration.• Remove the OEM bar-end weights (bar ends). If needed, follow the vehicle owner's/service manual.• Select the correct expansion sleeves (universal) for the handlebar's inner diameter. For larger diameters, slide the large sleeve over the small sleeve (see Figure A).• If vehicle-specific LGA adapters are included, attach them to the bar ends as specified. (When using LGA adapters, the universal expansion sleeve and cone are not used.)• Install the bar ends so the throttle grip moves freely with at least 1 mm clearance and returns to idle on its own (see Figure B).• Optional bar-end mirrors: Mount only on the 15 mm cylindrical surface (see Figure B).• All screw joints must be secured with liquid threadlocker. <p>General Mounting Notes</p> <ul style="list-style-type: none">• The grip area for control operation must not be restricted or narrowed.• The handlebar must move freely and must not contact the fairing or the tank.• Clamping surfaces must be free of oil and lubricants.• After the test ride, re-check all screws for tightness
	<p>The following must be observed during installation</p> <ul style="list-style-type: none">• Tighten the central M6 screws to 10 Nm.• All screw connections must be assembled with threadlocker

Mounting Position / Adjustment

Figure A

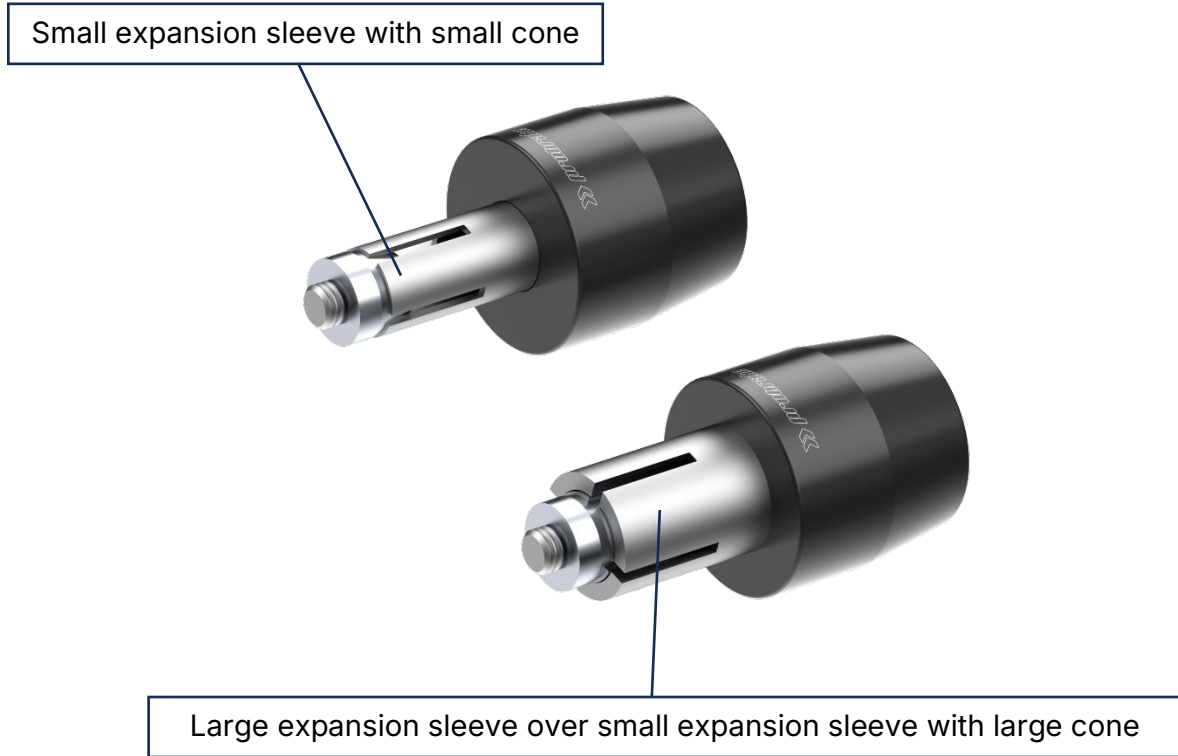
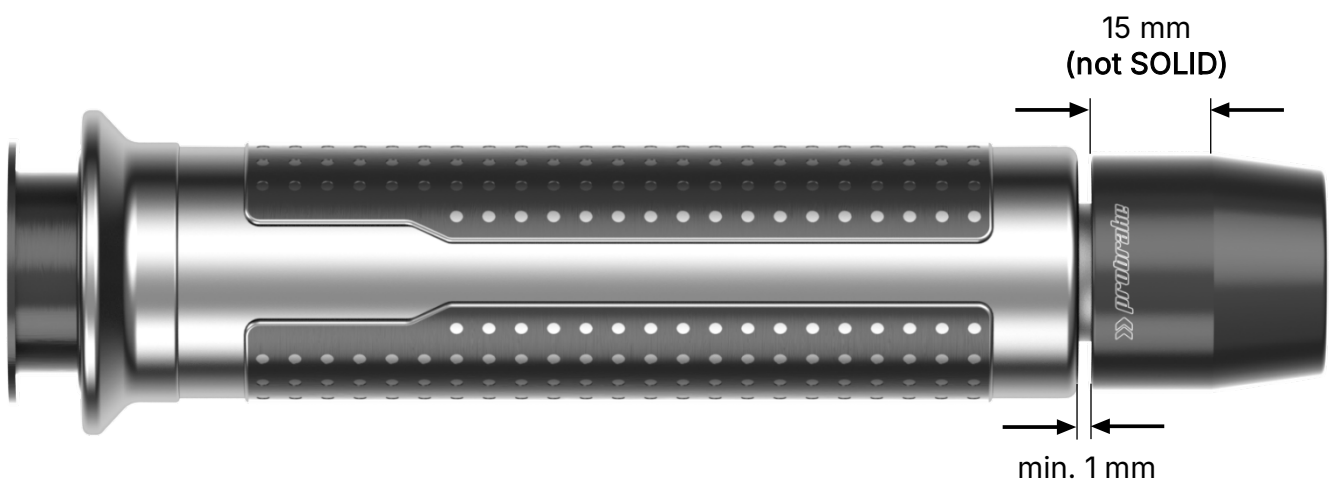

Figure B



Mounting Kits (LGA)

LGA01 	LGA02 	LGA03 	LGA04
LGA05 	LGA06 	LGA07 	LGA08
LGA09 	LGA10 	LGA11 	LGA12
LGA13 	LGA14 	LGA15 	LGA16
LGA18 	LGA19 	LGA20 	LGA21
LGA22 	LGA23 	LGA24 	

Here are some more probake quality products

STEEL BRAIDED HOSES



FOOTRESTS



BRAKE & CLUTCH LEVER



CRASH PADS & SAFETY



HANDLEBARS



BRAKE DISC & BRAKE PADS



ACCESSORIES & ATTACHMENT



STEEL BRAIDED KITS CARS



probrake GmbH
Fritz-Schieler-Str. 3
D-79331 Teningen

probrake.de

info@probrake.de

