

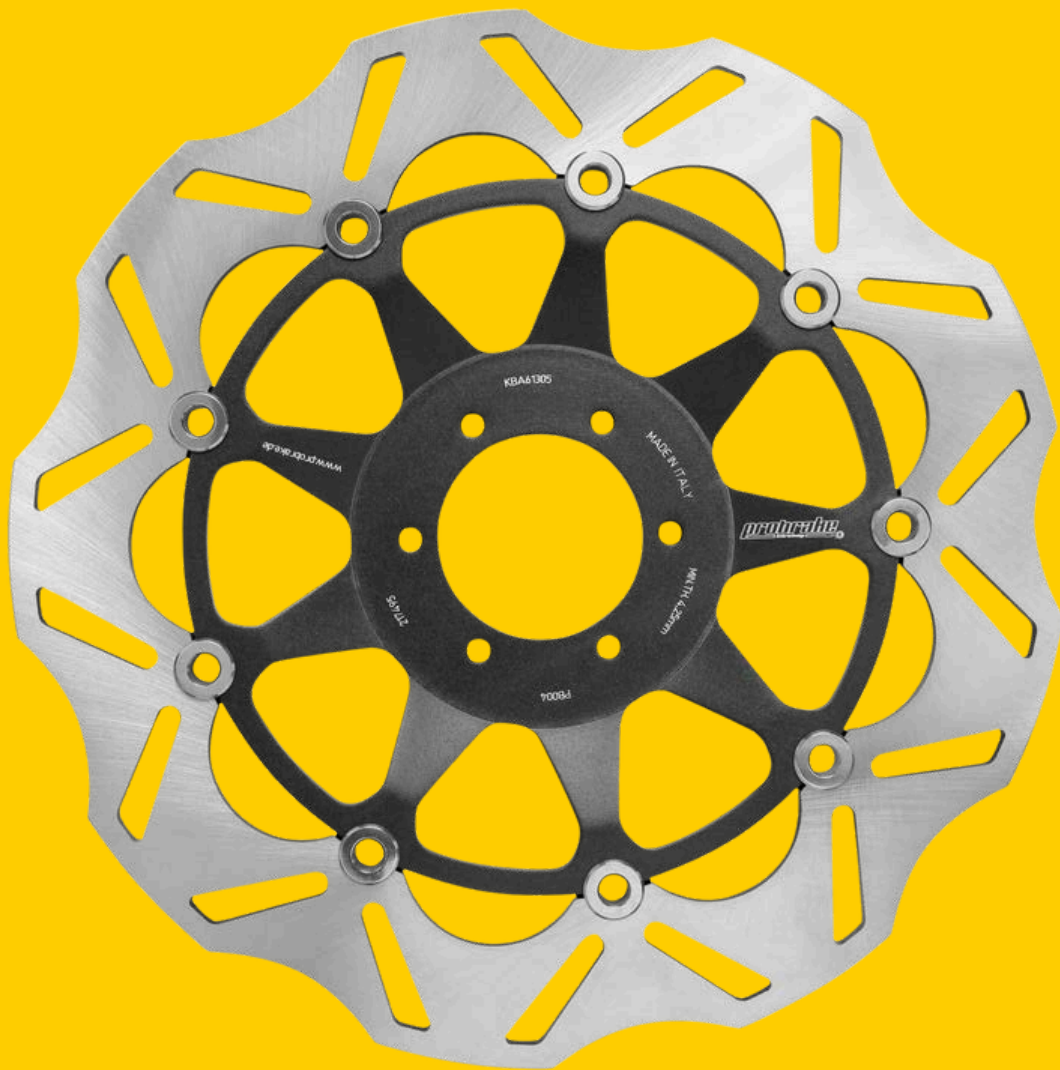

Installation Manual

Brake Disc - Force (Wave-Design)



probrake.de

General Safety Instructions for Installing brake disc



Installing brake discs requires technical knowledge and skill. Improper installation can lead to serious accidents and damage to the motorcycle. Please observe the following safety instructions:

Before Installation

- Tools: Use only recommended, suitable tools.
- Know-how: Perform the installation only if you have sufficient knowledge.
- Questions or issues: Contact a workshop with appropriately qualified personnel.
- Stability: Secure the motorcycle on a paddock/maintenance stand so it is stable.
- For motorcycles with dual discs, always replace both brake discs.
- Read first: Read this manual carefully and completely before starting

During Installation

- Protective equipment, if necessary: gloves, sturdy shoes, and safety goggles
- Torque: Tighten screws to the specified torque (use a torque wrench)
- Check components: Check all parts (brake disc, screws, spacer rings, ABS ring) for damage or wear before installing
- Work precisely and without using force on the components
- Secure screw connections only in accordance with the manufacturer's specifications (e.g., medium-strength screw lock)

After Installation

- Safety check: Verify the secure fit of all screws and components.
- Functional test of the brake when stationary.
- Test ride: Perform a careful test ride and watch for irregularities.

General Notes

- Brake discs are safety-related components. Improper installation can lead to brake failure.
- Ride defensively and attentively at first, and regularly check secure fit and free movement of all parts
- Replace damaged parts immediately; otherwise proper function cannot be guaranteed. Any manipulation such as welding, soldering, bending, or drilling the part is prohibited.
- probrake GmbH accepts no liability or warranty for damage resulting from combination with other accessories not tested by probrake, improper installation, or lack of maintenance.
- Damaged parts must be replaced immediately. Otherwise, proper functioning cannot be guaranteed. We prohibit any manipulation of the discs, such as welding, soldering, bending, or drilling.



ABE – General Operating Permit (Germany)

- The ABE (General Operating Permit) must always be carried with the vehicle in Germany.
- The instructions, information, and requirements of this ABE must be observed.
- Note on vehicles with individual operating permits (EBE) in accordance with §21 StVZO: The installation/assembly must be checked immediately by an appropriately recognized testing organization (see enclosed documents).
- Outside Germany, different legal regulations may apply.

Scope of Delivery (depending on model)

One brake disc (for multi-piece brake discs, pre-assembled)

- 1. Two-piece brake disc (pre-assembled)**
Inner ring and outer ring, pre-assembled, including floater and splined discs.
- 2. Outer ring (without mounting material)**
Outer ring only, no fastening or mounting material included, taken from the original.
- 3. Outer ring (including mounting material, optional, only for selected vehicles)**
Outer ring including floater and splined discs.

Please note the additional installation instructions

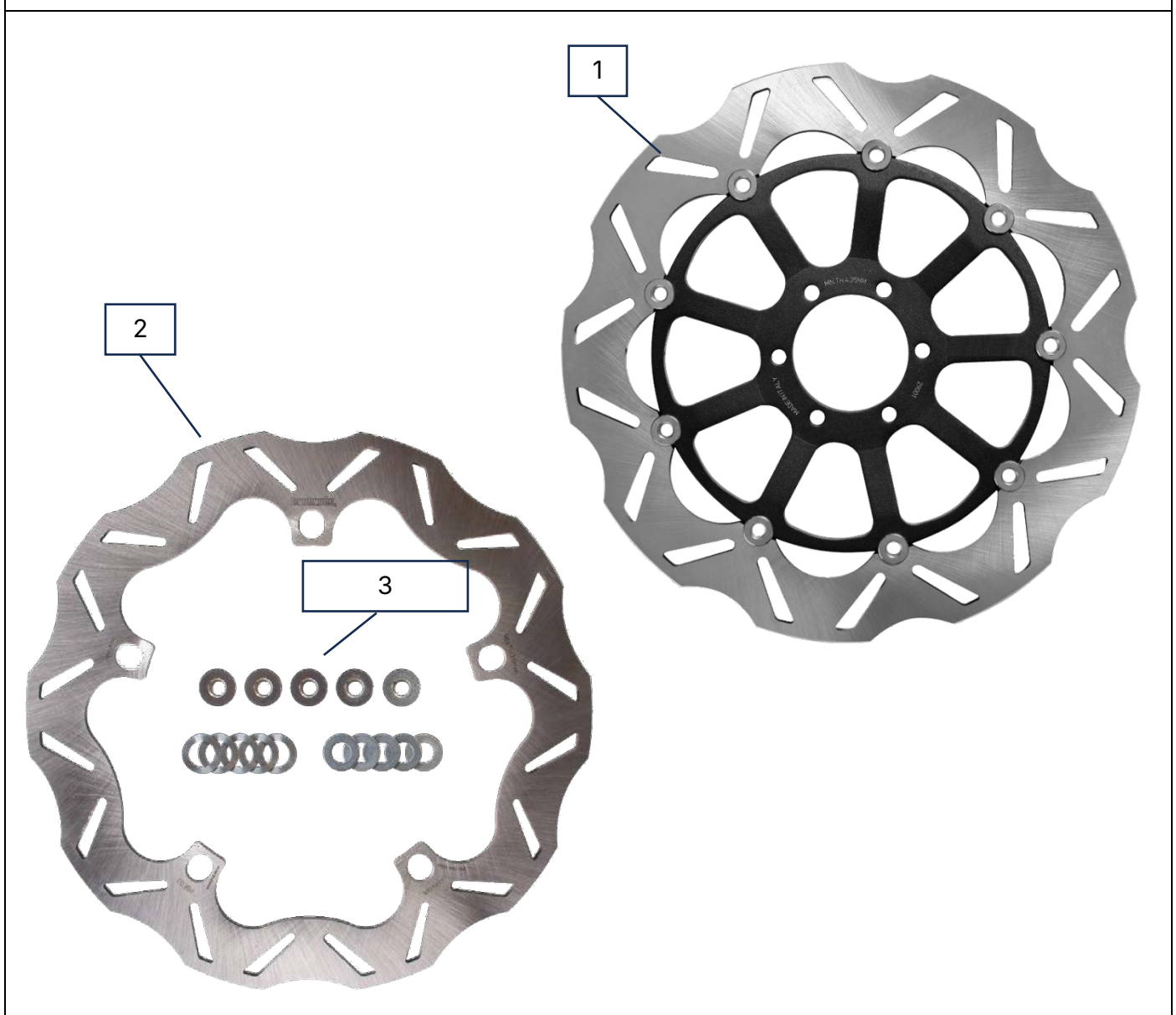

General Installation Notes – probrake Force Brake Discs



Preparation

- Park your motorcycle safely.
- For motorcycles with double discs: Always replace brake discs in pairs.
- Always use new brake pads with new brake discs.
- Check in advance whether ABS rings and/or spacer rings are installed on the vehicle and need to be reused.

Installation of the probrake FORCE "Wave" brake disc

- To remove the original brake disc(s), follow the instructions in the vehicle manufacturer's workshop manual.
- Check the contact surface on the wheel flange/rim for contamination (e.g., sealant, paint residue), burrs, and damage.
- Carefully remove any contamination so that the new brake disc sits flat (otherwise brake rubbing/noise may occur).
- Before installation, compare all dimensions of the new brake disc with the original (bolt circle, thickness, diameter, offset).
- Check whether there is a directional marking (arrow/ "Rotation") and align the disc accordingly.
- Recommended: Degrease the friction surface of the new brake disc with a suitable cleaner (e.g., brake cleaner) before installation so that the pads fit correctly.
- Place the new brake disc on the wheel.
- Always use the original mounting bolts. Damaged bolts must be replaced; only bolts approved by the manufacturer may be used.
- Tighten the screws crosswise, observing the manufacturer's torque specifications.
- Apply medium-strength screw lock (or comparable specification) to the threads of the fastening screws in accordance with the manufacturer's specifications.
- For vehicles with a spacer ring between the wheel flange and brake disc: Reuse the spacer ring and position it correctly.
- For vehicles with an ABS ring: Reuse the ABS ring according to the manufacturer's specifications and check that it is seated correctly.
- For motorcycles with double discs: Ensure that both brake discs are mounted in the same position.
- probrake brake discs may only be used with new brake pads.
- probrake brake discs have a wear indicator. If this indicator is below the minimum, the brake discs must be replaced.

Important information

- Check that the brake pistons in the brake calipers move freely. Stuck pistons can damage brake discs.
- Start by applying the brakes approx. 20 times with about 50% braking force.
- The pressure point may be soft at first, but will become more stable as the pads/discs adjust.
- Then apply the brakes several times with higher braking force and allow the brake system to cool down in between (no continuous braking).

More informations



Warranty / Use / Wear and tear

- probrake brake discs may only be used with new brake pads.
- The brake pads must be approved for road use (ABE or ECE-R90 form).
- probrake brake discs have a wear indicator. If this indicator is reached, the brake discs must be replaced.

Final note/disclaimer

These instructions are general guidelines. For vehicle-specific work steps and torque values, always refer to the vehicle manufacturer's workshop manual. The necessary work should only be carried out by suitably qualified persons. These instructions are general guidelines.



Nm

The following must be observed during installation:

- All torque values can be found in the specifications provided by the respective motorcycle manufacturer (workshop manual).
- Always tighten screws using a torque wrench.

Here are some more probake quality products

STEEL BRAIDED HOSES



FOOTRESTS



BRAKE & CLUTCH LEVER



CRASH PADS & SAFETY



HANDLEBARS



BRAKE DISC & BRAKE PADS



ACCESSORIES & ATTACHMENT



STEEL BRAIDED KITS CARS



probrake GmbH
Fritz-Schieler-Str. 3
D-79331 Teningen

probrake.de

info@probrake.de

